

22354E

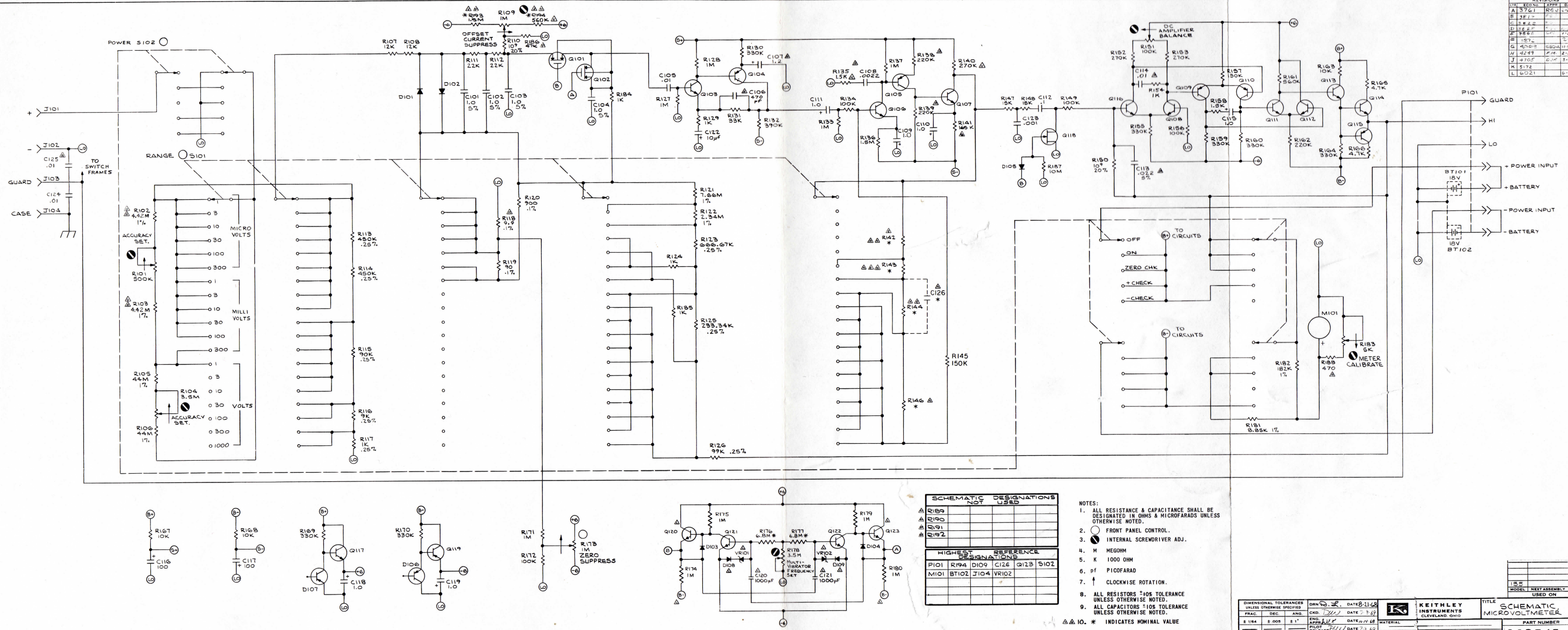

REV	DESCRIPTION	DATE
A	3761	8-1-57
B	3812	8-1-57
C	3842	8-1-57
D	3862	8-1-57
E	3872	8-1-57
F	3882	8-1-57
G	3892	8-1-57
H	3902	8-1-57
I	3912	8-1-57
J	3922	8-1-57
K	3932	8-1-57
L	3942	8-1-57

SCHEMATIC DESIGNATIONS NOT USED	
R189	
R190	
R191	
R192	

HIGHEST REFERENCE DESIGNATIONS	
P101	R194 D109 C126 Q123 S102
M101	B102 J104 V102

- NOTES:
1. ALL RESISTANCE & CAPACITANCE SHALL BE DESIGNATED IN OHMS & MICROFARADS UNLESS OTHERWISE NOTED.
  2. ○ FRONT PANEL CONTROL.
  3. ⊖ INTERNAL SCREWDRIER ADJ.
  4. M MEGOHM
  5. K 1000 OHM
  6. pF PICOFARAD
  7. ↑ CLOCKWISE ROTATION.
  8. ALL RESISTORS ±10% TOLERANCE UNLESS OTHERWISE NOTED.
  9. ALL CAPACITORS ±10% TOLERANCE UNLESS OTHERWISE NOTED.
  10. \* INDICATES NOMINAL VALUE

DATE	8-1-57	DATE	8-1-57
DESIGNED BY	...	CHECKED BY	...
APPROVED BY	...	DATE	8-1-57
RELEASED BY	...	DATE	8-1-57
DO NOT SCALE			

MODEL	155
TITLE	SCHEMATIC MICROVOLT METER
PART NUMBER	22354E

Figure 5-3. Model 155 Schematic Diagram, Dwg. No. 22354E